

REVISIONS			
REV	DESCRIPTION	DATE	APPROVED
A	RELEASE	9/7/98	

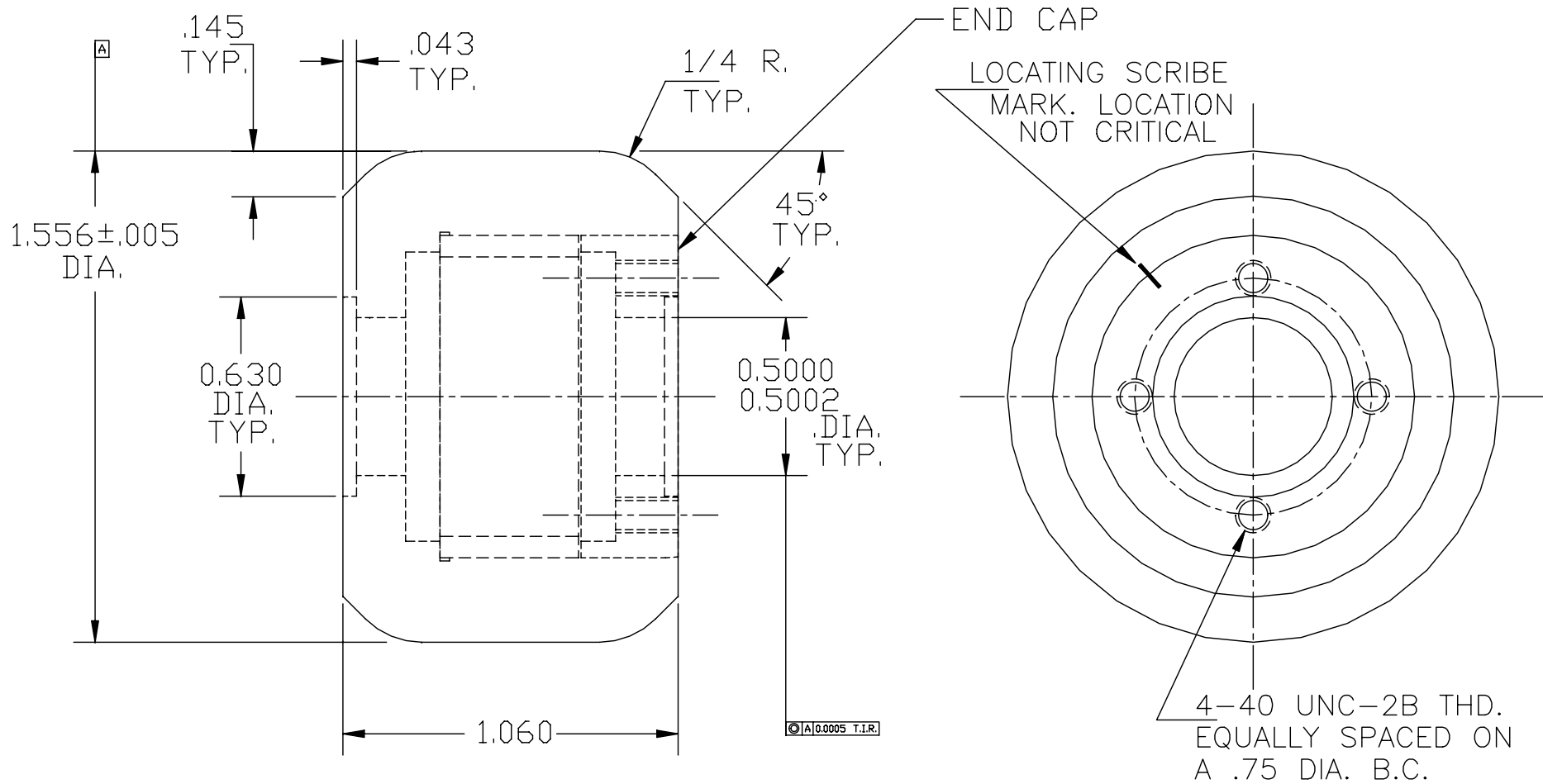

TOLERANCE	EXCEPT AS NOTED	CONTRACT		SCOT ELECTRICAL PRODUCTS DIVISION		
X.XX ±0.01	ALL DIMENSIONS APPLY AFTER HEAT TREATMENT AND PLATING  BREAK ALL SHARP CORNERS .005-.015 THREADS PER MIL-S-7742 MACHINE FINISH 125 RUNOUT ON COAXIAL DIAMETERS TO BE .005 T.I.R. MAXIMUM FILLET RADII .02 REMOVE ALL BURRS	DRAWN HUTCH	9/7/98	BONDERS 11670504LL, 60515		
X.XXX ±0.005		CHECKED N.KHANT	6/4/99	TITLE GYRO ROTOR		
X.XXXX ±0.0001		STRESS			SIZE Cage Code: DWG.No.	
XX* ±1*		QUALITY ASSURANCE B.FANK	6/4/99	ONFF5 10HM7-003C		
FRAC. ±1/64		RELIABILITY			SCALE SHEET OF	
CHAMFERS 45° ±2*		PROJ. ENG.				
		APPROVED				
		APPROVED				